

J.L. WINGERT CO.

P.O. Box 6207 • Garden Grove, CA 92846-6207 / 11800 Monarch Street • Garden Grove, CA 92841-2113
 Phone (714) 379-5519 • Fax (714) 379-5549 ■ Southwest Region • Phone (602) 470-1015
 30998 Huntwood Avenue, Unit 105 • Hayward, CA 94544-7033 • Phone (510) 487-5310 • Fax (510) 487-5137
 On the Internet: www.jlwingert.com • Email: customerservice@jlwingert.com

MANUFACTURING: Mixers, Bypass Feeders, Filter Feeders, Bromine Feeders, Sample Coolers, Sludge Traps, Separators, Separator Systems, Tank Stands,
 Tank Package Systems, Glycol Feed Systems, Coupon Racks, Control Stations, NEMA Enclosures, Custom Packaged Systems and Specialty Welding

Specification Sheet #032014 Rev. "A" (4/01)

DOME BOTTOM FIBERGLASS FEEDERS

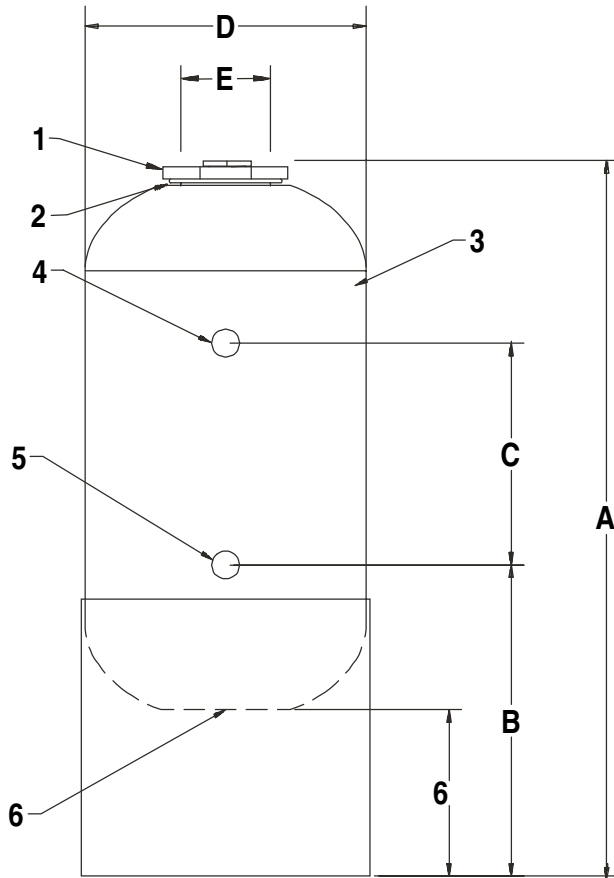

PARTS, MATERIALS AND SPECIFICATIONS:

KEY	PART	SPECIFICATIONS
1	3206	CLOSURE: 4" CPVC closure (O-ring included), 1" PVC Plug
2		O-RING: EPDM
3		BODY: Fiberglass
4		OUTLET: 3/4" FNPT
5		INLET: 3/4" FNPT
6		DRAIN: 1" FNPT
MAX. PRESSURE		150 PSI (10.4 BAR)
MAX. TEMPERATURE		120° F (66° C)

FILL CAPACITY:

MODEL	GALLONS	LITERS	VOLUME
FRP-DB-5	5.1	19.3	1,178 in ³
FRP-DB-12	12.1	45.8	2,795 in ³
FRP-DB-16	16.7	63	3,857 in ³

DIMENSIONS, CUBE AND WEIGHT:

KEY	FRP-DB-5	FRP-DB-12	FRP-DB-16
A	25 7/8"	46 7/8"	60 3/4"
B	11 1/4"	11 1/4"	11 1/4"
C	8"	28 7/8"	43"
D	10 1/8"	10 1/8"	10 1/8"
E	4"	4"	4"
CUBE	10 1/2" X 10 1/2" X 26"	10 1/2" X 10 1/2" X 47"	10 1/2" X 10 1/2" X 61"
WEIGHT	24 lbs. (10.9 kgs.)	51 lbs. (23.2 kgs.)	71 lbs. (32.2 kgs.)

Note: All dimensions are +/- 1/8". All weights are approximate. All dimensions are subject to change without notice.